

REMOTE CONTROLLED DOG TRAINING COLLARS

OWNER'S MANUAL



Dogtra Company

1250 E. 223rd Street, Suite 119
Carson, CA 90745

Tel : (310) 522-1800

Fax : (310) 522-1805

Toll Free: 1-888-811-9111



dogtra 3500NCP Super-X Series



CONTENTS

• OVERVIEW	2
• MAIN FEATURES	3
• PRODUCT SAFETY AND HEALTH STATEMENTS	4
• PACKAGE CONTENTS	5
• DESCRIPTION OF TRANSMITTER PARTS	6
• DESCRIPTION OF COLLAR/RECEIVER PARTS	20
• DESCRIPTION OF BATTERY CHARGER ...	24
• TESTING YOUR <i>dogtra 3500NCP Super-X Series</i>	25
• FITTING THE COLLAR ON THE DOG	27
• CHARGING THE BATTERIES	29
• RECEPTION	32
• ACCESSORIES	33
• BASIC MAINTENANCE	34
• WARRANTY AND REPAIR INFORMATION	38

THANK YOU FOR PURCHASING THE WORLD'S
FINEST DOGTRA e-COLLAR!

***dogtra* 3500NCP Super-X Series**
Designed for X-treme training conditions

The 3500NCP is labeled the Super-X because it has X-tra features, X-ceptional range and is designed for X-treme training situations.

Features include a one-mile range, fully waterproof transmitter and receiver, 127 levels of Nick and Constant stimulation along with a non-stimulating pager/vibration. You can also choose between "Regular" and "Mild" stimulation adjustment for highly sensitive dogs.

It also features an LCD window on the transmitter that displays the intensity level along with a three bar battery life indicator. A Lithium Polymer battery is included in the units, which allow a 2-hour rapid charge.

The ***dogtra* 3500NCP Super-X** also comes in a two-dog model (3502NCP Super-X).

The 3500NCP Super-X sets the standard for X-treme versatility and performance in the e-collar industry.

MAIN FEATURES

- Easy-to-use, ergonomic transmitter.
- Rheostat dial allows for gradual increases in stimulation intensity with no jumps between levels (0-127).
- Two-dog models allow the trainer to control two different dogs from one transmitter without the hassle of handling unnecessary parts.
- ***dogtra* 3500NCP Super-X** has a 1-mile range.
Stimulation type - "Nick", "Constant" and non-stimulating pager/vibration.
- ***dogtra* 3500NCP Super-X Series** uses a new Lithium Polymer battery that provides a 2-hour rapid charge.
- Fully Waterproof collar/receiver and transmitter.
- No external antenna on the collar/receiver.
- One-charger system allows the transmitter and receiver(s) to be charged at the same time.
- Over 8000 different identity codes to prevent signal match-up with other e-collars.
- Easily visible blue LCD screen displays exact level of stimulation and can be seen in the dark or low light conditions.
- Three bar battery life indicator and LED colored indicator to show remaining battery life.

PRODUCT SAFETY AND HEALTH STATEMENTS

Proper e-collar use

Dogtra e-collars are intended for the sole purpose of behavior modification of dogs. They are not intended for human use or use on other animals. Dogtra Company does not assume any liability for improper use of the Dogtra e-collar.

Aggressive dogs

Dogtra does not recommend using the e-collar to correct dogs that are aggressive towards other dogs or people. In many such cases the dog will associate the stimulation with the other dog or individual and become even more aggressive. Dog aggression is best treated by a dog-training specialist.

Interference with other electronic devices

Dogtra's industry-leading technology filtering system ensures minimal interference with other electronic devices (garage door openers, pacemakers, etc.). Our digital microprocessor offers thousands of unique codes to eliminate frequency match-up with other Dogtra e-collars.

Inadvertent activation

If the constant button is held down for 12 seconds or more the unit will automatically shut down. It will reactivate when the button is released.

dogtra COLLAR PACKAGE CONTENTS

- Transmitter
- Receiver (two collar receivers for *dogtra* two-dog models)
- Lithium Polymer Battery charger and splitter cable
- Test light
- Owner's manual
- Carrying case

DESCRIPTION OF TRANSMITTER PARTS

DESCRIPTION OF TRANSMITTER PARTS

dogtra 3500NCP Super-X transmitter (1-dog)

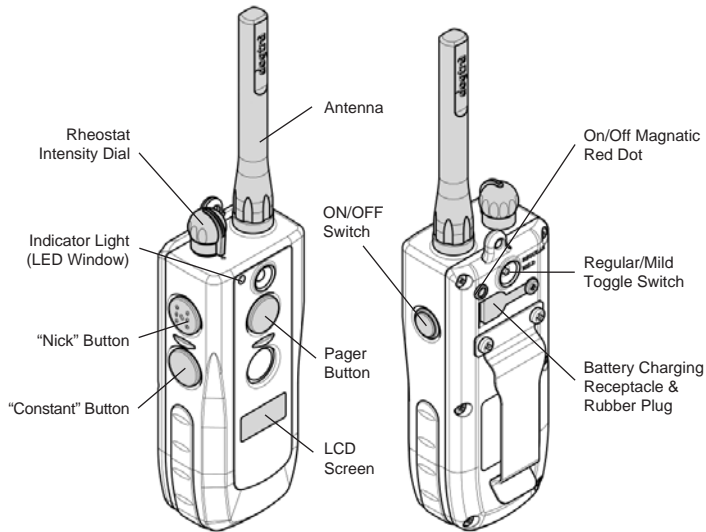

DESCRIPTION OF TRANSMITTER PARTS

DESCRIPTION OF TRANSMITTER PARTS

dogtra 3502NCP Super-X transmitter (2-dog)

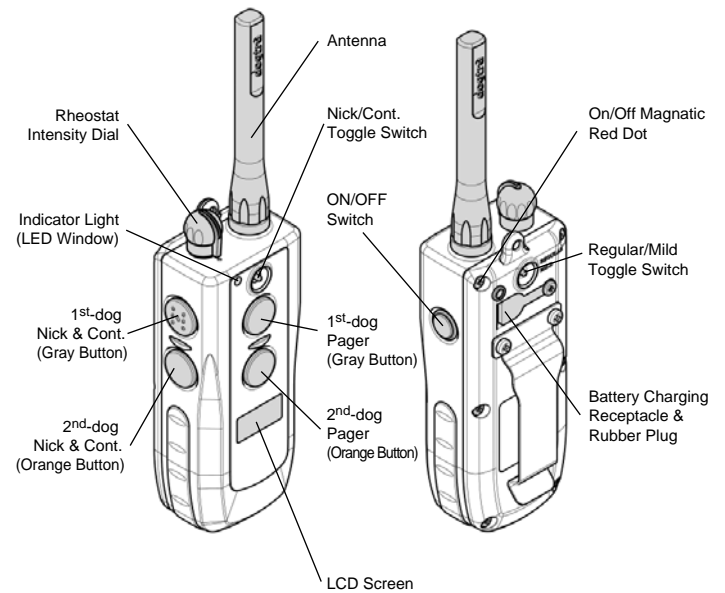

DESCRIPTION OF TRANSMITTER PARTS

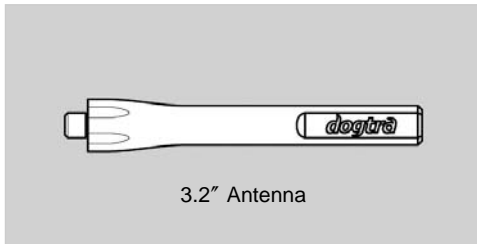

Transmitter Antenna

A 3.2" antenna is supplied with the **dogtra 3500NCP Super-X Series**.

The antenna must be fastened to the transmitter before using the unit.

DESCRIPTION OF TRANSMITTER PARTS

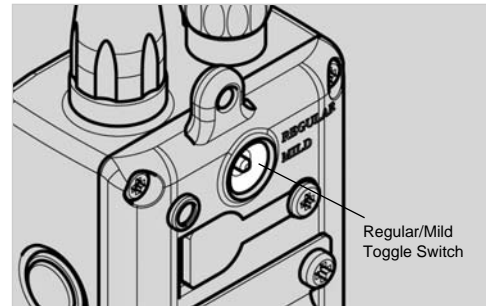

Regular/Mild Toggle Switch

The Regular/Mild toggle switch is located on the back of the transmitter near the top.

The Regular/Mild toggle switch allows you to select between Regular and Mild stimulations. When the toggle switch is put into the upper position, it is in the Regular Mode. When the toggle switch is put into the lower position, it is in the Mild Mode.

“Regular” has 127 stimulation levels: (0) is the lowest level and (127) the highest. The LCD will

DESCRIPTION OF TRANSMITTER PARTS

display the intensity level when you have the unit set in the “regular” mode.

“Mild” has 63 stimulation levels: (0) is the lowest and (L63) the highest.

This feature gives the trainer a much wider range in the power band for highly sensitive dogs.

The LCD display will show (L) along with the intensity level (0-L63) when your unit is in the “Mild” setting.

DESCRIPTION OF TRANSMITTER PARTS

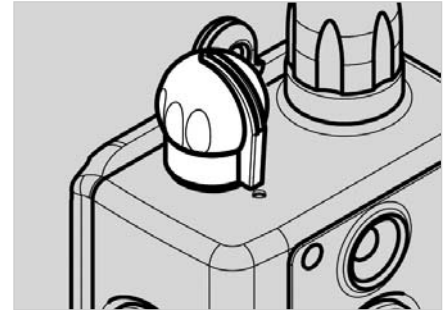

Rheostat Intensity Dial

The Rheostat Intensity Dial is located on the top of the transmitter: (0) being the lowest level and (127) being the highest while in the Regular Mode.

While in the Mild Mode, your level options will be (0) being the lowest, and (L63) being the highest. The LCD screen will display the (L) to indicate that the toggle switch is positioned in the Mild Mode.

DESCRIPTION OF TRANSMITTER PARTS

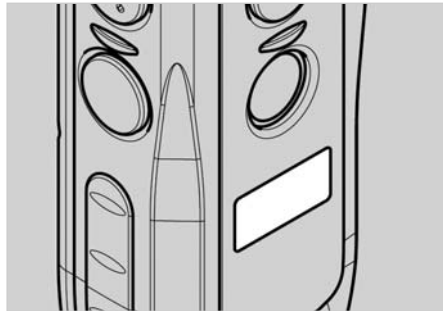

LCD Screen

The LCD screen indicates the stimulation level (0-127) for Regular or (0-L63) for Mild on the screen.

The LCD battery life indicator shows 3 bars at full charge, 2 bars at medium charge and 1 bar when it needs to be charged. The battery life indicator only specifies the remaining charge for your transmitter. To find the remaining charge for your receiver, observe the LED screen on the collar/receiver.

When it emits a: (**Green color** = fully charged, **Amber color** = medium charge, **Red color** = needs charge).

DESCRIPTION OF TRANSMITTER PARTS

Care for LCD Transmitters in Cold Temperature

In cold temperatures (10 degrees F or below), the Liquid Crystal Display (LCD) on your transmitter may be dim or slow to respond. Wait until the display becomes visible before selecting any training level.

Even though the LCD screen might be dim or slow to respond, when you push the Nick or Constant button, the transmitter will still function properly. In the occurrence of extremely cold weather, the LCD screen might take a moment to respond causing the Intensity level to freeze at that current level. In this situation, if you turn the Rheostat Intensity Dial, and the intensity level on the screen does not increase, yet you emit an electrical stimulation, the level will be in agreement with the new changed intensity level.

In this situation, it is ideal to either wait until your transmitter is back to working order before emitting a correction, or while holding the constant button down slowly turn the Rheostat Intensity Dial while watching your dog's reaction. Do not turn the Rheostat Intensity Dial at a rapid increase because the collar/receiver will emit a static correction based on the level of the Rheostat Intensity Dial, which might not be correctly reflected on the LCD screen.

DESCRIPTION OF TRANSMITTER PARTS

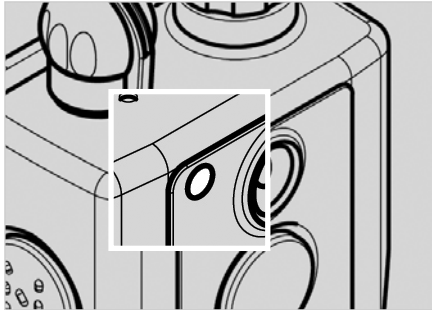

Transmitter Indicator Light (LED Window)

The transmitter LED indicator light is located near the Rheostat Intensity Dial. It will flash every 4 seconds when the transmitter has been turned on. The color of the light indicates the status of battery life. It flashes green when the battery is fully charged and turns to amber when the battery is at medium charge. It is acceptable to charge your unit even at medium charge without any damage incurred to your collar. When the transmitter indicator emits a blinking red light, the battery needs to be recharged.

(**Green** = full charge, **Amber** = medium charge, **Red** = needs charge).

DESCRIPTION OF TRANSMITTER PARTS

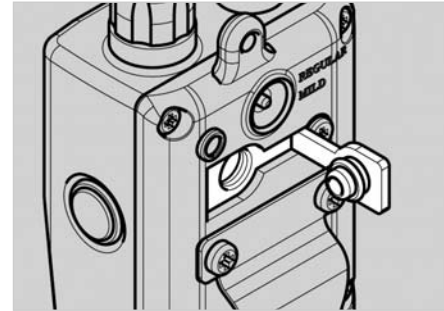

Transmitter Battery Charging Receptacle & Rubber Plug

Located on the backside of the transmitter, the charging receptacle is covered by a rubber plug. Insert one end of the battery charging cable into the receptacle to charge the battery (See Battery Charging Procedure on page 30).

After charging is completed, close the receptacle with its rubber plug to make sure dirt or water does not get inside.

BUTTON FUNCTION

dogtra 3500NCP Super-X Series (1-dog)

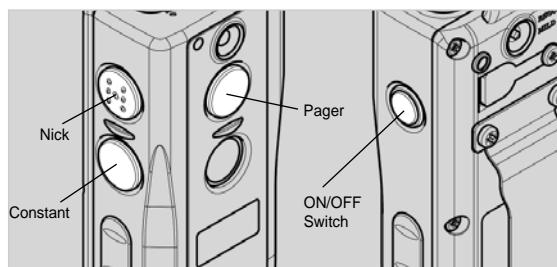

The transmitter for the *dogtra 3500NCP Super-X* single dog unit has four buttons (one on the face of the transmitter, two on the left side and one on the right side).

“Nick” Button

The “Nick” button is located on the top left. It is imprinted with the letter “N” for an easy, clear selection. When the “Nick” button is pushed the receiver emits a single, rapid pulse of electrical stimulation.

“Constant” Button

The “Constant” button is located on the bottom left. Pressing the “Constant” button gives continuous stimulation as long as the button is pushed, for up to 12 seconds. If the button is not released after 12 seconds, the stimulation will automatically turn off as a safety feature. The collar will be ready to be reactivated once the button has been released.

“Pager” Button

The pager button is located on the face of the transmitter. Pressing it will give non-stimulating vibration as long as the button is depressed, for up to 12 seconds.

Transmitter Power ON/OFF

The button on the right side of the transmitter is the “ON/OFF” button that activates the transmitter and LCD screen only.

To turn the transmitter on, press the “ON/OFF” button on the right side until the LCD screen illuminates.

To turn the transmitter off, press the “ON/OFF” button on the right side of the transmitter. When the LCD screen displays “OFF” release the button.

DESCRIPTION OF TRANSMITTER PARTS

dogtra 3502NCP Super-X Series (2-dog)

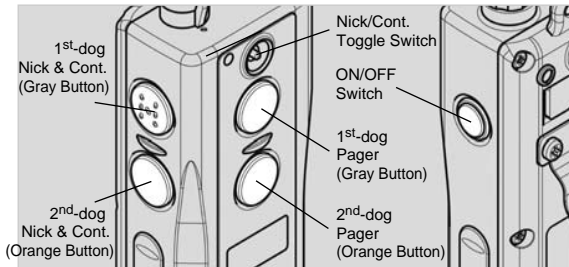

The **dogtra** 3502NCP Super-X two-dog unit has five buttons and a toggle switch on the transmitter.

Two on the face of the transmitter, two on the left side, and one on the right side.

“Nick” & “Constant” Toggle Switch

Located on the face of the transmitter is a toggle switch. The toggle switch has a setting for “Nick” and another for “Constant”. The color-coordinated buttons (orange for the orange receiver/collar and gray for the black receiver/collar) will implement the desired stimulation based on the toggle switch

DESCRIPTION OF TRANSMITTER PARTS

setting.

When either the orange or gray stimulation button is pressed and the toggle is set on “Nick” the receiver emits a single, rapid pulse of electrical stimulation.

When you press either the orange or gray stimulation button, and the toggle is set on “Constant”, the receiver emits a continuous stimulation as long as the button is pushed, for up to 12 seconds to the corresponding collar. If the button is not released after 12 seconds, the stimulation will automatically turn off as a safety feature. The collar will be ready to be reactivated once the button has been released.

“Pager” Button

The pager buttons are located on the face of the transmitter. The orange button corresponds with the orange receiver/collar and the gray with the black receiver/collar. Pressing it will give non-stimulating vibration as long as the button is depressed, for up to 12 seconds.

DESCRIPTION OF COLLAR / RECEIVER PARTS

DESCRIPTION OF COLLAR / RECEIVER PARTS

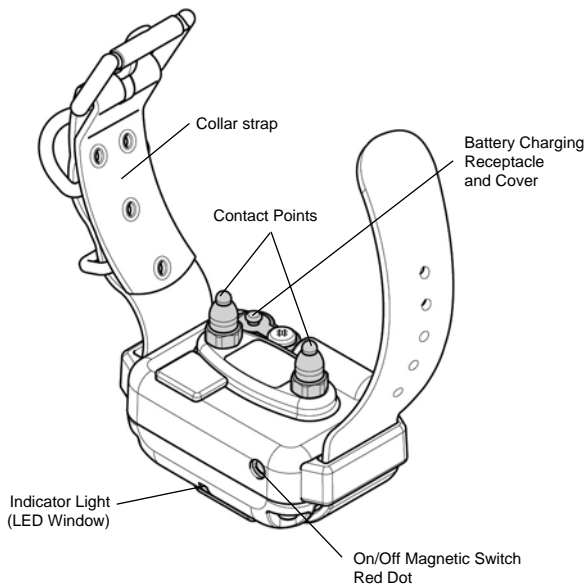

DESCRIPTION OF COLLAR / RECEIVER PARTS

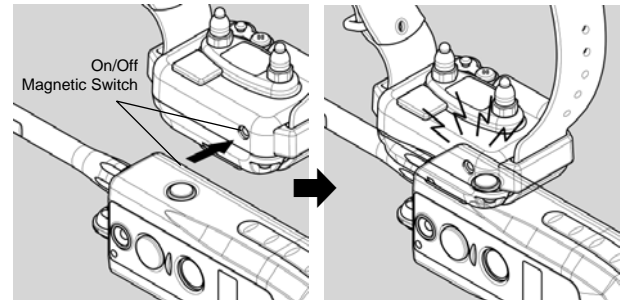

Receiver ON/OFF Magnetic Red Dot

To activate the receiver/collar, place the red dot on the back of the transmitter to the red dot on the collar/receiver. Hold the two red dots together for a moment until the LED light on the receiver/collar comes on.

To deactivate the unit, repeat the same procedure holding the two red dots together momentarily. The LED light will turn red for a brief moment indicating that the collar/receiver is now shut off.

DESCRIPTION OF COLLAR / RECEIVER PARTS

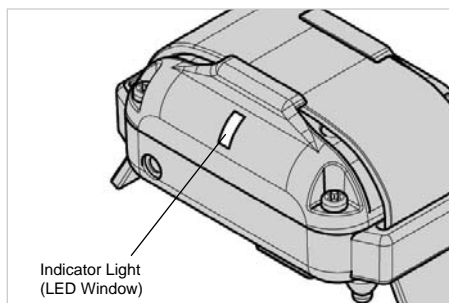

Receiver Indicator Light (LED window)

Located on the front of the receiver/collar, the indicator light comes on and blinks once every 4 seconds after the collar has been turned on. The color of the LED indicates the battery life of the receiver.

(**Green** = full charge, **Amber** = medium charge, **Red** = needs charge)

When the “Constant” button on the transmitter is pushed, the collar indicator light will glow steadily (either green, amber, or red based on the remaining battery life), as long as you hold the button down, for up to 12 seconds.

When the “Nick” button is pushed, the light comes on for a fraction of a second.

DESCRIPTION OF COLLAR / RECEIVER PARTS

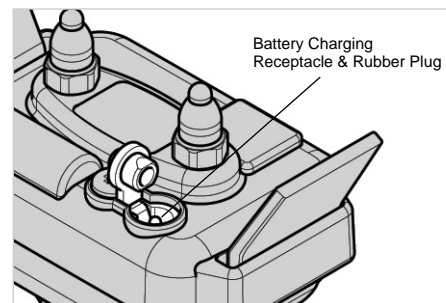

Receiver Battery Charging Receptacle & Rubber Plug

On the inside of the collar receiver, next to the collar strap, is a battery-charging receptacle with a rubber plug.

Internal Antenna

All Dogtra E-collars have non-exposed antennas that are located inside the collar/receiver.

BATTERY CHARGER

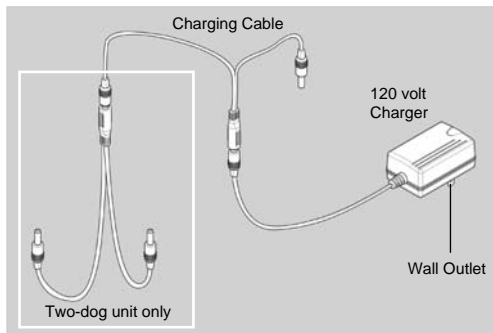

The battery charger and charging cables allow you to charge both the transmitter and receiver at the same time. The battery charger is designed for a 120-volt wall outlet. (European 230-volt AC chargers and 12-volt field charger for Lithium-Polymer batteries for your automobile are also available.)

To use the battery charger for the two-dog unit, combine both sets of battery charging (splitter) cables as shown. This enables you to charge the transmitter and both receivers at the same time.

NOTE : Only use Dogtra-approved Lithium-Polymer Battery Chargers for your Dogtra e-collar. This will prevent any damage that can be incurred from attempting to use a different charger.

TESTING YOUR *dogtra* 3500NCP Super-X Series COLLAR

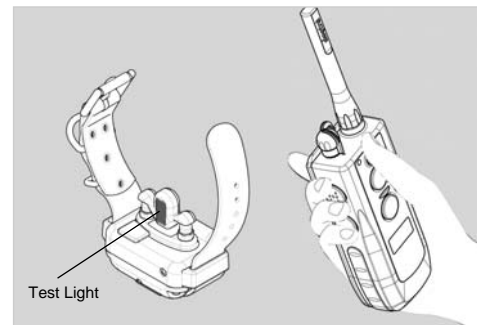

1. To activate your *dogtra* 3500NCP Super-X Series place the red dot on the back of the transmitter to the red dot on the collar/receiver. Hold the two red dots together for a moment until the green colored LED indicator light comes on.
2. Place the Test light included in the package contents on the contact points as shown in the diagram.

TESTING

3. Turn the transmitter on by pressing the blue button on the right side of the transmitter until the LCD screen illuminates. The LCD screen shows the amount of battery life remaining and the LED blinks once every 4 seconds.
4. Watch the test light as you push the “Nick” button on the transmitter. It should light for just a moment.
5. Watch the test light as you push the “Constant” button on the transmitter. It should light for as long as the button is pressed. However, as a safety feature, the collar/receiver will automatically shut off stimulation if the constant button is depressed for 12 seconds or longer.
6. Turn the Rheostat Intensity Dial on the transmitter clockwise and then counterclockwise. The test light should glow brighter with higher levels of stimulation and dimmer with lower levels. When you change the intensity dial, the number on the LCD screen will change as well.
7. Pressing the “Pager” button on the front of the transmitter causes the collar to vibrate for up to 12 seconds. The collar will reactivate when you push the button again.

NOTE : The test light may not come on if the intensity level is set below level ten.

FITTING THE COLLAR ON THE DOG

FITTING THE COLLAR ON THE DOG

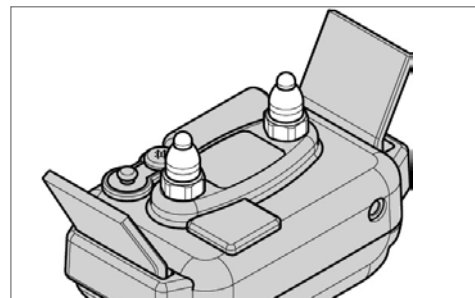

The collar should be fitted so that the Surgical Stainless Steel contact points press firmly against the dog’s skin. You should be able to fit a finger in between the contact point and your dog’s skin.

A loose fit can allow the collar to move around on the dog’s neck. When this happens, the contact points may rub the skin and cause irritation. If the collar is too loose, electrical contact will be inconsistent and your corrections will be inconsistent also.

Dogtra uses Surgical Stainless Steel contact points and Anti-microbial plastic to protect the dog's skin.

ATTENTION!

Avoid having the dog wear the collar for more than 8 hours out of every 24-hour period. Leaving the points on the same spot for extended periods of time can cause skin irritation. If the dog is to wear the e-collar for long periods, occasionally reposition the collar so that the contact points are moved to a different spot on the dog's neck.

INTENSITY SELECTION

The 3500NCP Super-X series has a Rheostat Intensity Dial on the top of the transmitter. (0 is the lowest and 127 is the highest). Remember that you will need to adjust the setting (upward or downward) depending on your dog's temperament and threshold for stimulation. Also, as the dog's attitude changes, especially during times of increased excitement or distraction, you might need to adjust the intensity level.

NOTE : The stimulation intensity can be adjusted even while the stimulation is in use.

CHARGING THE BATTERIES

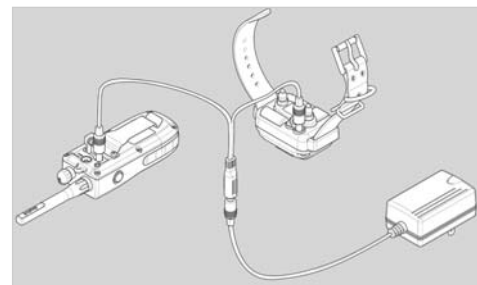

dogtra 3500NCP Super-X Series uses Lithium-Polymer batteries.

1. Charge the unit before using the unit for the first time.
2. Do not charge the batteries near any flammable substances.
3. Fully charge the batteries if the unit is to be stored without use for a period of 3 months or more.

Recharge the unit if:

- The indicator light on the collar is emitting a red color.

CHARGING THE BATTERIES

- If the 3 bar indicator on the transmitter LCD shows just 1 bar.
- The indicator light on the transmitter or receiver will not come on.
- The indicator light on the transmitter or receiver comes on momentarily, but will not stay on when the “Constant” button is pushed.

Battery Charging Procedure

Note : The unit has a partial charge when it leaves the Dogtra facility, upon receipt of the collar, be sure to give it a full 2-hour initial charge before the first use.

1. Attach the charging cables to both the transmitter and receiver(s), as shown on page 29
2. Plug the charger into a 120-volt wall outlet or, if using the accessory field charger, plug into a cigarette lighter only for Lithium-Polymer battery. (Use a 230-volt European charger for Europe.) When properly plugged in, all indicator lights should glow red. During the charging process, the unit will shut off. Once the battery cable is unplugged from the unit after a full charge, you will need to turn the unit on again before use.

CHARGING THE BATTERIES

3. The Lithium-Polymer battery is fully charged within 2 hours. The lights will stay red during the charging process. The red light will change into a steady green light when the battery is fully charged. (When you disconnect the charger after finishing the charge, you will need to restart the units).
4. After charging, cover the battery charging receptacles with the rubber plugs on the transmitter and receiver.

NOTE : Only use Dogtra-approved batteries, chargers, and accessories for your Dogtra e-collars. When a charger is not in use, disconnect it from the power source.

Reception

The **dogtra 3500NCP Super-X Series** collar has a range of 1 mile. Depending on the way you use your transmitter, the transmitter range may vary.

Hold the transmitter away from your body and avoid touching the antenna, to get the greatest range.

For maximum signal strength, keep your unit properly charged.



Maximum Range



Typical Range



Minimum Range

ACCESSORIES

The following items may be purchased separately by calling our customer service at (888) 811-9111. You may also browse the selection at www.dogtra.com.

European Charger

Designed for use with 230V AC electrical outlets in Europe.

Field Auto Charger (for Lithium-Polymer Battery only)

Designed for use with the 12-volt cigarette lighter in your car.

BASIC MAINTENANCE

Be sure that the rubber charging plugs are always secured when the collar is in use. If your plugs break or are ripped, please contact Customer Service at info@dogtra.com or (888) 811-9111 to obtain replacements.

After each session, carefully inspect your unit for any missing parts, or casing damage. Broken casings on either the receiver or transmitter may affect the waterproof guarantee of the unit. The transmitter antenna should be secured and tight for optimum performance. Rinse the unit after each session and clean off any dirt or debris.

Storage Maintenance

Your unit should be fully charged for 2 hours before extended storage. During storage, the unit should be charged every 3 months for 2 hours, and once before the first use.

When traveling, try to store your units in room or slightly warmer temperatures, do not transport the unit exposed in extreme climates.

Troubleshooting:

If you suspect your unit is malfunctioning please refer to the “Troubleshooting Guide” before you send your unit in for service.

If you have any questions or concerns, you may direct your inquiries to info@dogtra.com or call (888) 811-9111.

TROUBLESHOOTING GUIDE

1. My dog is not reacting to the collar.

- Make sure the receiver is turned on. Place the two red dots together to activate the receiver. Push the blue button on the transmitter until it illuminates to activate the transmitter.
- Be sure the collar strap is tight enough so both contact points are touching the dog’s skin.
- The contact points may be too short for the dog. To place an order for longer contacts appropriate for your dog, please call (888) 811-9111.
If you are already using the longest contact point available, you might need to trim down the hair on the dog’s neck so both contact points are touching the dog’s skin.
- The intensity level may be too low for your dog. Keep increasing the stimulation until the dog responds usually by neck movement, head shaking, looking over his shoulder, etc. (response may be very subtle so pay attention.)

2. The test light comes on, but I do not feel any stimulation.

- Your tolerance may be higher than your dogs, or your skin very thick, so you may need to try the unit on your fingertips where sensitivity is higher. Be sure both contact points are touching your fingertips.
- The battery may be low, check the LED light for battery life.
- If you have a full charge, and you have done all of the above, your unit may need to be serviced. Please contact Customer Service at info@dogtra.com or (888) 811-9111.

3. The transmitter has no range, or stimulation is less when the dog is farther away.

- The antenna(s) may be damaged. To order parts please contact Customer Service at (888) 811-9111.
- The range indicated on the unit's box is for flat terrain. Heavy brush, trees, hills or moisture will affect the range of your unit. For best range, hold the transmitter vertically above your head. Try also moving to higher ground.
- Any electrical conductors will affect the range, such as cars, chain-link dog runs, metal buildings, radio towers. For best results, operate away from these structures.

4. My collars are not holding a charge.

- The batteries might not be charged properly, or the charger, splitter and the charging port needs to be looked at. If you suspect your charger/splitter is not functioning properly please contact Customer Service at info@dogtra.com or (888) 811-9111. You can send in your charging units in to have us inspect them.
- The charging pin may be damaged. Inside the charging port, there is a metal pin that should be standing straight up and stiff. If the pin is wobbling, broken or missing, you will need to send the unit in to the Repair's Dept. The charging port must be clean prior to charging, clean the dirt out with a cotton swab and some rubbing alcohol. If the dog is in salt-water, be sure to rinse the receiver and charging port with clean water.
- Your batteries may need to be replaced. You can replace them yourself by ordering the parts from Dogtra. This is the only time you should open the unit, any other unauthorized servicing of the unit voids your limited lifetime warranty.

WARRANTY AND REPAIR INFORMATION

LIMITED LIFETIME WARRANTY

(Applicable for units purchased after December 31, 2005 that are registered within 30 days of original purchase).

- To qualify for the Limited Lifetime Warranty: Product registration must be completed online at www.dogtra.com or via telephone at (888) 811-9111. For international customers, please call us at (310) 522-1800.
- Dogtra's Limited Lifetime Warranty provides:
 - 1-year warranty for batteries.
 - 1-year warranty for the Yapper Stopper No-Bark collars.
 - 2-year warranty for parts and labor awarded to the original retail purchaser of the e-collars.
- Dogtra's Limited Lifetime Warranty does not provide its warranty if the product is not registered within 30 days of purchase and/or if the product is resold. The warranty will become void and all repairs will be subject to

applicable labor fees. Dogtra does not provide replacement on defective units or provide refunds after 30 days from the original date of purchase.

- All parts are covered under the warranty for the life of the product. After the two-year warranty has expired, the labor cost will be determined based on the model type, year, and the extent of repair.
- The Limited Lifetime Warranty expires five-years from the date a unit is discontinued in production by Dogtra Company.
- Warranty does not cover:
 - Misplaced or lost units.
 - Replacement costs of either the transmitter or receiver is owner's responsibility).
 - Water damage of models that are not waterproof.
 - Damage done by dog or owner, neglect, or improper maintenance.
 - Warranty will be voided if the unit(s) have been altered or had unauthorized service.

WARRANTY AND REPAIR INFORMATION

Procedure for Repair Work:

Shipping to Dogtra for warranty work is the owner's responsibility. The cost for shipping (via regular ground service) back to the customer is covered by Dogtra Co. within the continental United States. Any expedited shipping service will be at the owner's expense. Dogtra is not responsible for loss of training time or inconvenience while the unit is in our warehouse for repair work. Dogtra does not provide loaner units or any form of compensation during the repair period.

A copy of the sales receipt showing purchase date is required before warranty work is begun.

Write a note briefly explaining the problem and include your name, address, city/state/zip code, daytime phone number and evening phone number. Or you can visit our web site at www.dogtra.com to fill out a Service Request Form. If repair costs are not covered under warranty, we will call you for credit card information once the work has been completed. For any questions concerning your Dogtra

WARRANTY AND REPAIR INFORMATION

products call us Toll Free at 1-888-811-9111. Our operating hours are between 8:30am-4:00pm Pacific Standard Time.

Send repair units to:

Dogtra Company
1250 E. 223rd Street, Suite 119
Carson, CA 90745

MEMO

MEMO

42

43

MEMO

MEMO

44

45